

MANUAL TUBE BENDING MACHINE

Model: UZ(Series)



UZ Line series tube benders are manual machines with gear motor driven bending movement. These machines are the most economical solution of mandrel tube bending for small productions.

TECHNICAL DATA:

MODEL	Max. pipe dia. (mm)	Max. wall thickness (mm)	Max. centerline bending radius (mm)	Max. bending angle (°)	Bending speed (°/SEC)	Motor power (KW)	Mandrel length (mm)	Bending accuracy	Approx. weight (kg)	Dimension (LXWXH) (mm)
UZ 32	32	2	275	190	60	2.2	1650	±0.5	220	1950X850X925
UZ 42	42	2	250	190	40	4	2600	±0.5	750	3150X1000X1050
UZ 51	51	3	250	190	35	5.5	3150	±0.5	1000	3700X1000X1050
UZ 76	76	4	250	190	20	7.5	3150	±0.5	1100	4000X1000X1050

STANDARD ACCESSORIES:

- Manual Clamp
- Mandrel System
- Manual Support
- Manual bending angle adjustment with switch system
- Gear Motor driven bending movement



TUBE BENDING TOOLINGS:

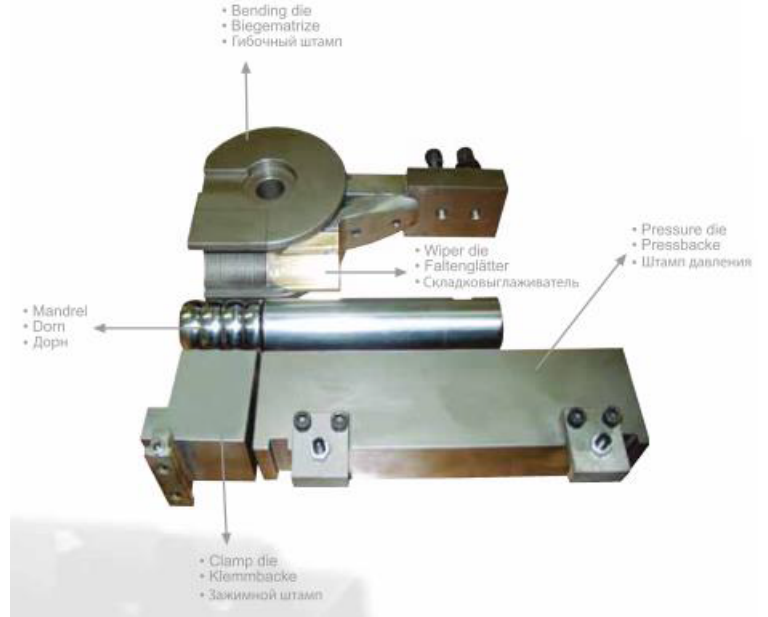

• Special Mandrels for Profiles
• Spezielle Dornen für Profile
• Специальные дорны для профилей



• Mandrels
• Dornen
• Дорны

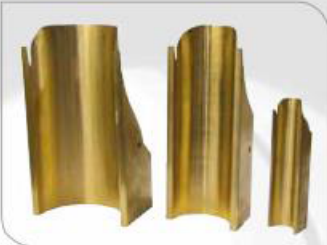

• Wiper Die
• Falteglätter
• Складковыглаживатель



• Collars
• Spreitzdornen
• Двухконный дорн



• Standard Mandrel
• Standard Dorn
• Стандартный дорн

• Amiko Mandrel with 1 Ball
• Amiko Dorn mit 1 Ball
• АМКО дорн с 1 шариком

• 4 Ball Mandrel
• 4 Ball Dorn
• Дорн с 4 шариками

